

Dear Partners,

Due to the variety of models and manufacturers of 6-way valves, we have made a drawing that allows you to determine on site, whether the AUTO (AUTO MINI, MONO) automatic flushing unit fits to this valve, whether adaptation of the AUTO unit is required or installation of the AUTO unit on this valve is impossible.

Recall that the AUTO (AUTO MINI, MONO) automatic flushing unit can be installed on 6-way valves with 1.5" or 2" connection.

For installers and service technicians, we have prepared a training video that allows them to properly mount the AUTO unit on a 6-way valve. The video can be downloaded from our website:

<https://darin7.ru/files/auto-install.mp4>

Be sure to subscribe to our Telegram channel: @darin77777

Sincerely, DARIN

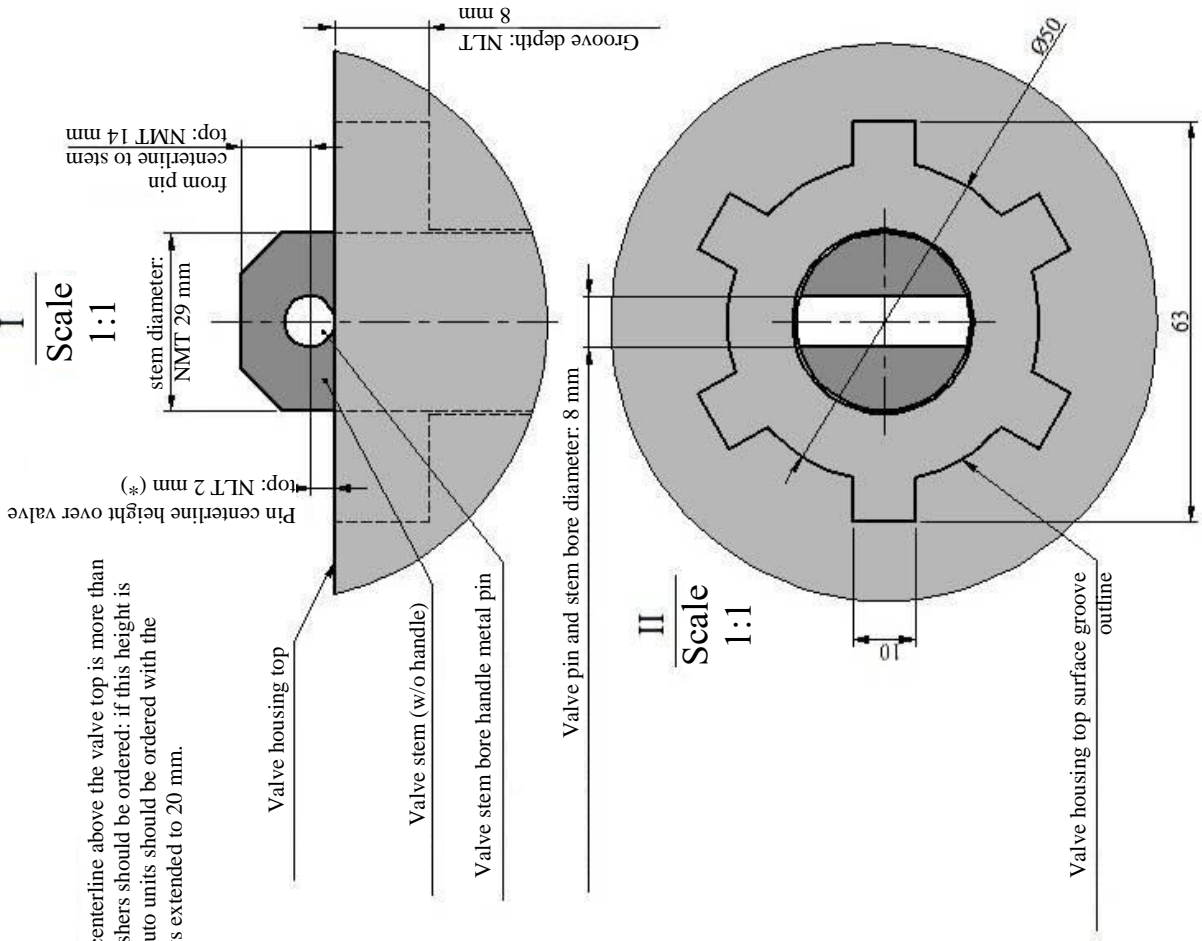

*) If the height of the pin centerline above the valve top is more than 5 mm, additional C-washers should be ordered: if this height is more than 7 mm, the Auto units should be ordered with the support retention screws extended to 20 mm.

1 1/2" and 2" 6-way valve sizes to evaluate compatibility with Auto and Mono units

